

KUBOTA WHEEL LOADER

R310/R310B



Kubota

Power and Performance – the core of the versatile R310 & R310B wheel loaders and the cornerstone of the legendary tradition that is Kubota.

You demand it, and we deliver with the all new R310 and R310B wheel loaders. You receive all the standard appointments you would expect in a Kubota such as a powerful engine, responsive handling, high reach & dump clearance, comfortable seating and ROPS/FOPS safety features, but you also get a host of standards not readily found on competitor models. An articulated design, long wheelbase, and even high visibility. When it comes to unmatched power and all-around performance, the R310 and R310B are the right choices to handle all your wheel loader jobs.

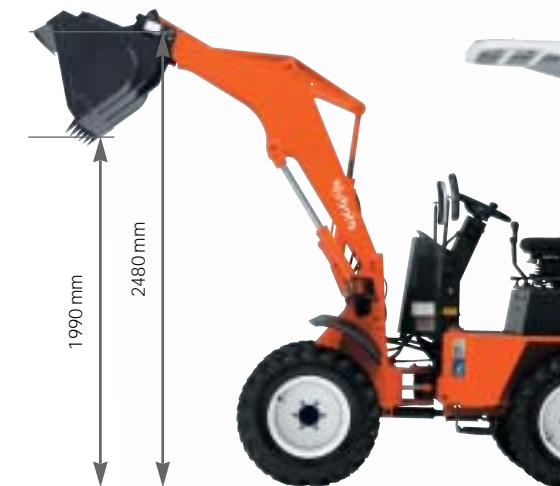

Dumping clearance

For easy dumping, even into trucks with high beds, the Kubota R310 and R310B have a really satisfactory dumping clearances for their class.

Load sensing transmission

This feature enables our wheel loaders to automatically shift from low speed/high torque to high speed/low torque as load conditions vary.

Safety Starting System

To prevent mishaps, our Safety Start System will not allow the engine to start until the electric shuttle shift is in neutral and the parking brake is applied.

Independent 2-system-type brake

A hydraulic main brake and a mechanical-type parking brake offer a high level of control. To ensure responsiveness even in mud, their wet-discs are protected by being completely sealed.

Front attachment

Quick couplers and auxiliary hydraulics make it simple to attach numerous versatile attachments.





Responsive power steering

You'll work longer and manoeuvre easier, even in tight spaces, with smooth-operating, light-touch power steering.

ROPS/FOPS canopy

Superior protection is provided by a Roll-Over Protective Structure and Falling Object Protective Structure. Both ROPS and FOPS meet the strictest ISO standards.

Fully adjustable suspension seat

To provide a high level of comfort to a wide range of operators, the suspension seat adjusts according to the operator's weight, plus has hip support and recline.



Rear frame oscillation

An oscillating body enables the machine to keep its traction force more stable even on rough terrain, so jobs can be performed more comfortably.

Exceptional serviceability

From simple daily maintenance to more complex repairs, a lockable, wide-opening, flip-up engine cover provides easy access to most areas of the wheel loader's engine.

Articulated Body

With our advanced articulated-type design, the front and rear wheels follow the same track line for greater maneuverability, more flexibility, and an overall tighter turning radius.

Kubota M-type engine

Kubota's E-TVCS engine combines all the impressive qualities that have always been associated with the Kubota name—impressive power, high reliability, fuel efficiency, and low vibration.



SPECIFICATIONS

WORKING RANGE

Model		R310 / R310B		
Engine	Model	Kubota		
	Type	V1305-E-RP		
	Output	kW/rpm	18/2600	
		PS/rpm	25/2600	
	Number of cylinders	4		
Displacement	cc	1335		
Dimensions	Overall height	mm A	2450	
	Overall length	mm B	3980	
	Overall width	mm C	1345	
	Height to hinge pin	mm D	2480	
	Dump angle fully raised	E	46°	
	Dump height	mm F	1990	
	Reach fully raised	mm G	750	
	Wheelbase	mm H	1450	
	Ground clearance	mm I	230	
	Tread	mm J	1050	
	Angle of articulation (each way)	K	41°	
	Operational Specifications (with standard bucket)	Standard bucket capacity	m ³	0,26
		Bucket breakout force	daN (kgf)	1650 (1680)
Tipping Load, straight (ISO 8313) (canopy/cab)		kg	1040/1220	
Tipping Load, full turn (ISO 8313) (canopy/cab)		kg	870/1030	
Max. Lifting Capacity (ISO 8313)		daN (kgf)	880 (900)	
Loader raise time		sec	3,9	
Loader lower time		sec	2,5	
Bucket dump time		sec	1,0	
Draw bar pull		daN (kgf)	1570 (1600)	
Operating weight (canopy/cabin)		kg	1990/2220	
		with backhoe (canopy/cab)	kg	2140/2415
Standard tires		10-16,5-4RP		
Operational Specifications (with fork)		Tipping Load, full turn (ISO 8313)	kg	550/650
	Max. Payload (EN474-3) 80%	kg	440/520	
	Max. Payload (EN474-3) 60%	kg	330/390	
Drive train	Transmission		Load Sensing Transmission	
	Travel speed		km/h 0~14	
	Brakes	Service	Enclosed, Self adjusting Wet Disc	
Parking		Spring Applied, Hydraulic Released Wet Disc		
Fluid refill	Fuel tank	ℓ	26	
	Hydraulic system	ℓ	20	
	Hydraulic reservoir	ℓ	24	
Backhoe Specifications	Reach from centerline of swing pivot	mm A	2975	
	Overall operating height	mm B	2800	
	Loading height	mm C	1765	
	Digging depth (Maximum)	mm D	2100	
	Side shift	mm	820	
	Digging force bucket	kg	775	
	Digging force dipperstick cylinder	kg	520	

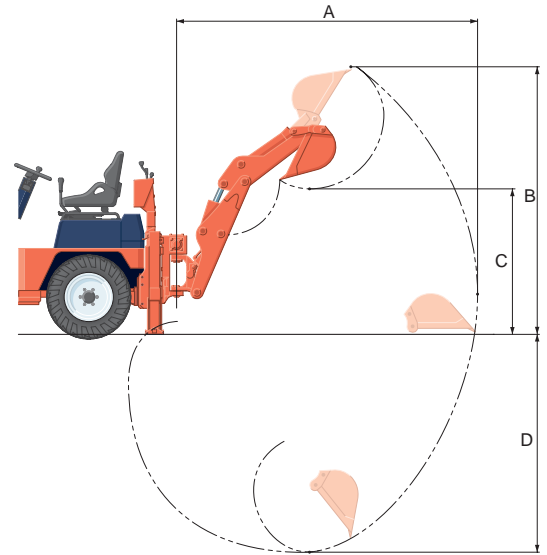
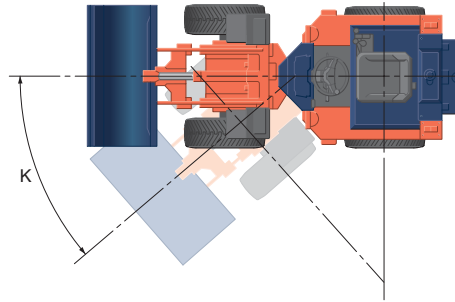
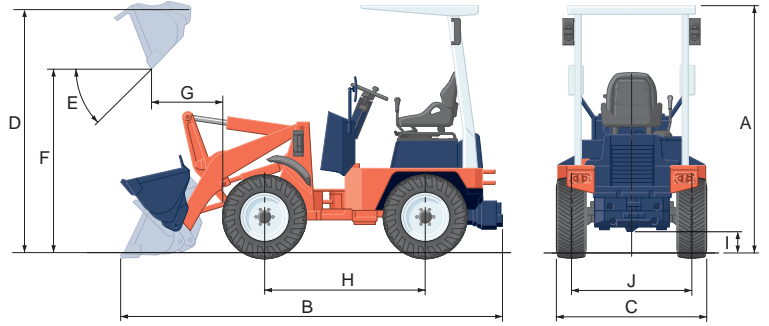

NOTE : Above dimensions are based on the machine with Quick Coupler made in Germany, Standard Bucket, Weight and ROPS/FOPS Canopy and Cab. Mean Value and value for use on concrete roads are given for tipping load and operating load. Specifications Subject to change without Notice.

KUBOTA EUROPE S.A.S.

19 à 25, Rue Jules - Vercruysse - Z.I.
 B.P. 50088, 95101 Argenteuil Cedex France
 Téléphone : (33) 01 34 26 34 34
 Télécopieur : (33) 01 34 26 34 99